

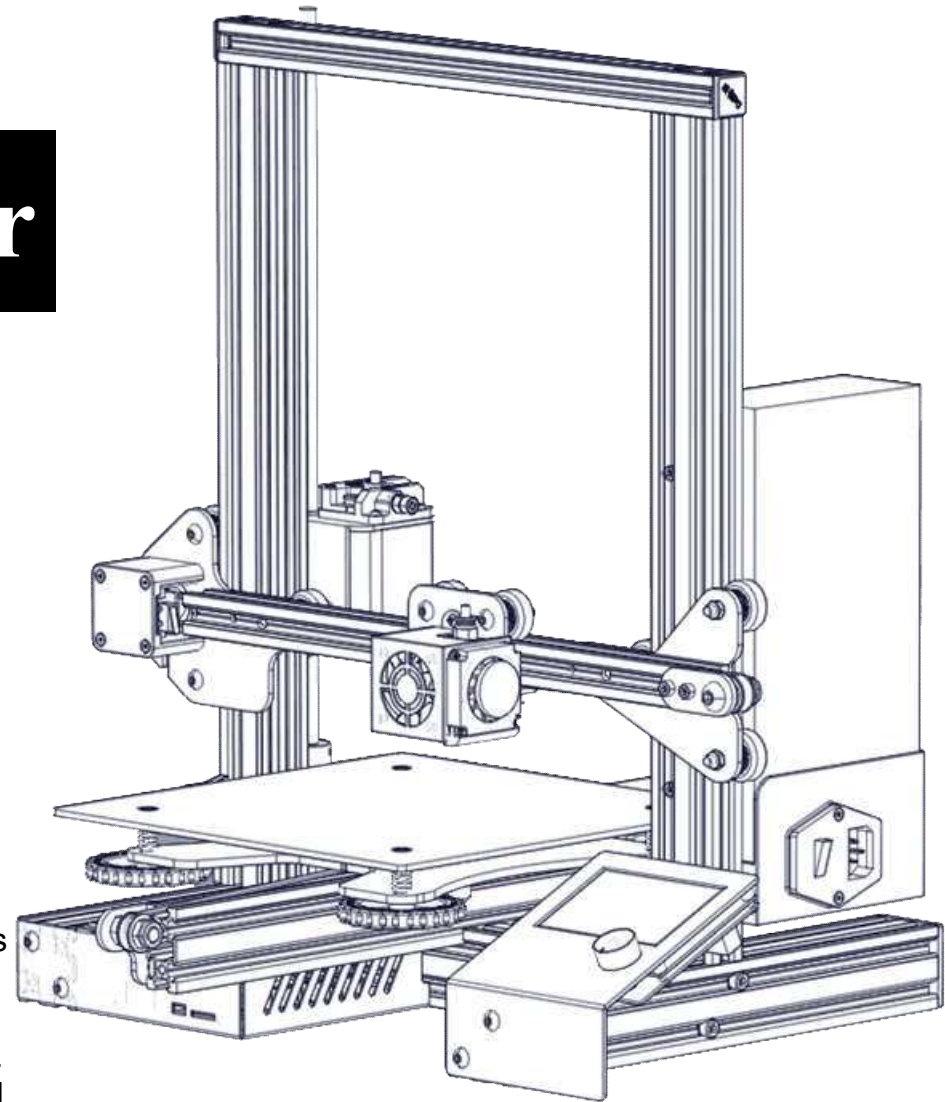

Ender 3 3D Printer

Instructions for assembly

- ◆ This guide is for the Ender 3 3D printer.
- ◆ Select the correct input voltage to match your local mains (220V or 110V)
- ◆ Because of software/hardware upgrades and model differences, new revisions may not be listed in this guide.
- ◆ Detailed instructions for use are available on the SD card.



List 1

Assemblies

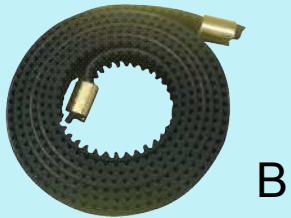
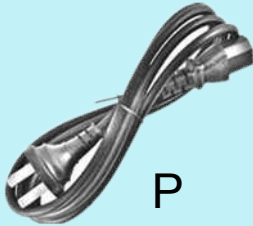
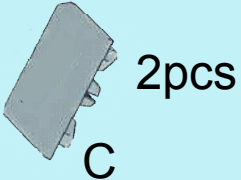
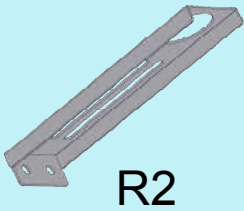
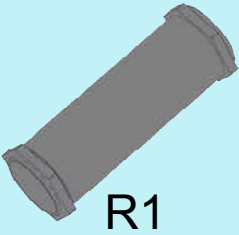
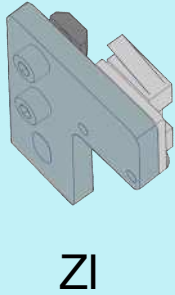
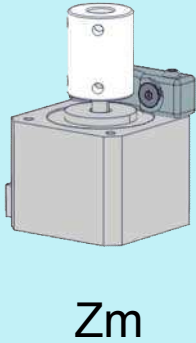
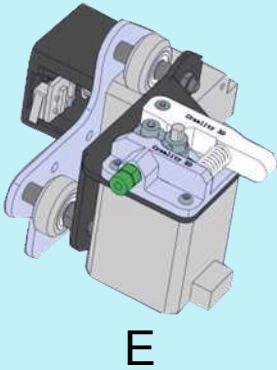
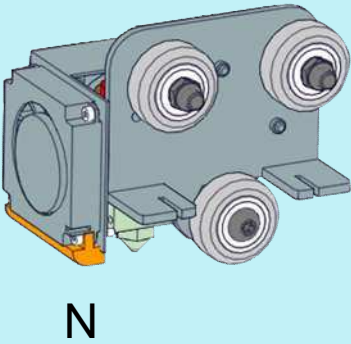
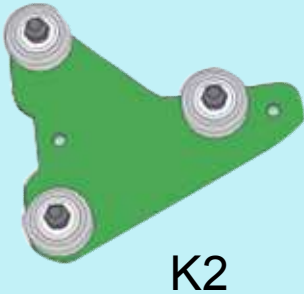
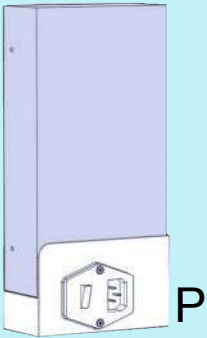
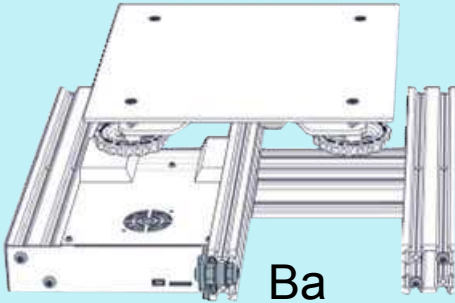
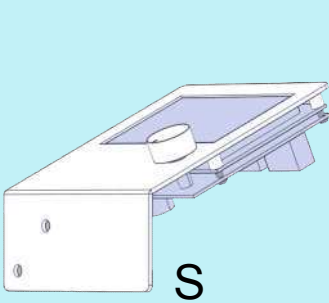

List 2

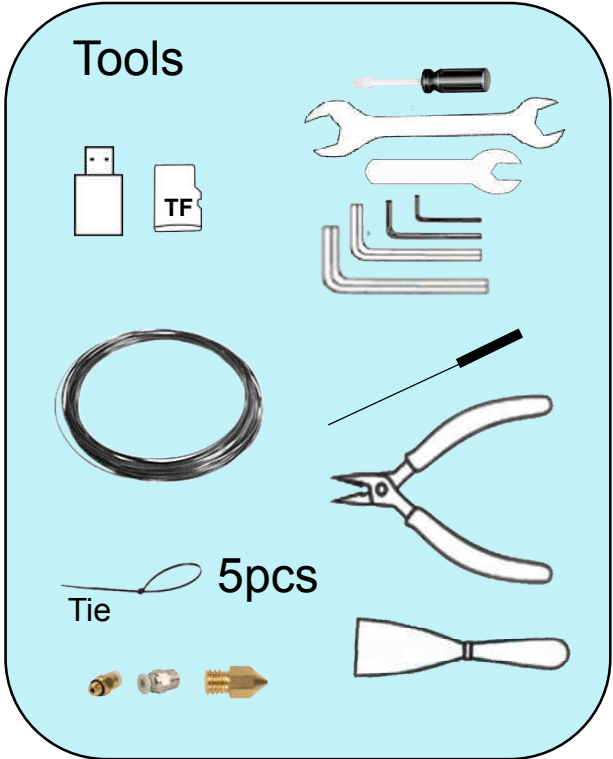
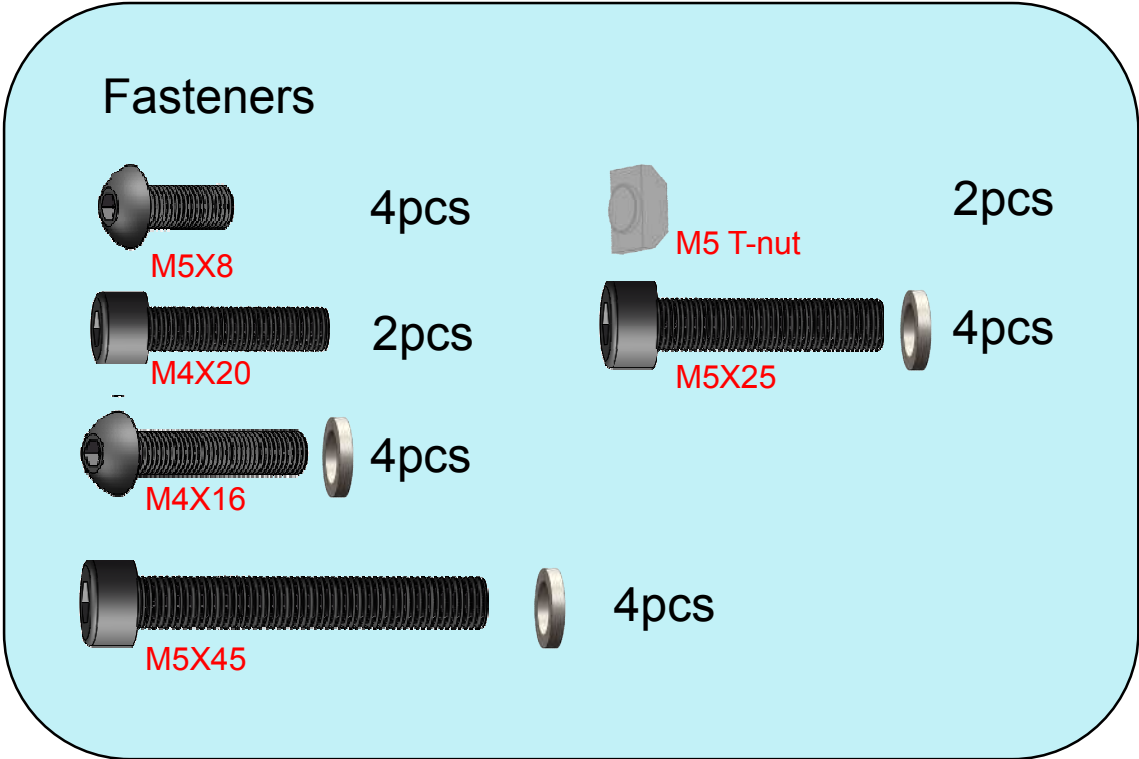
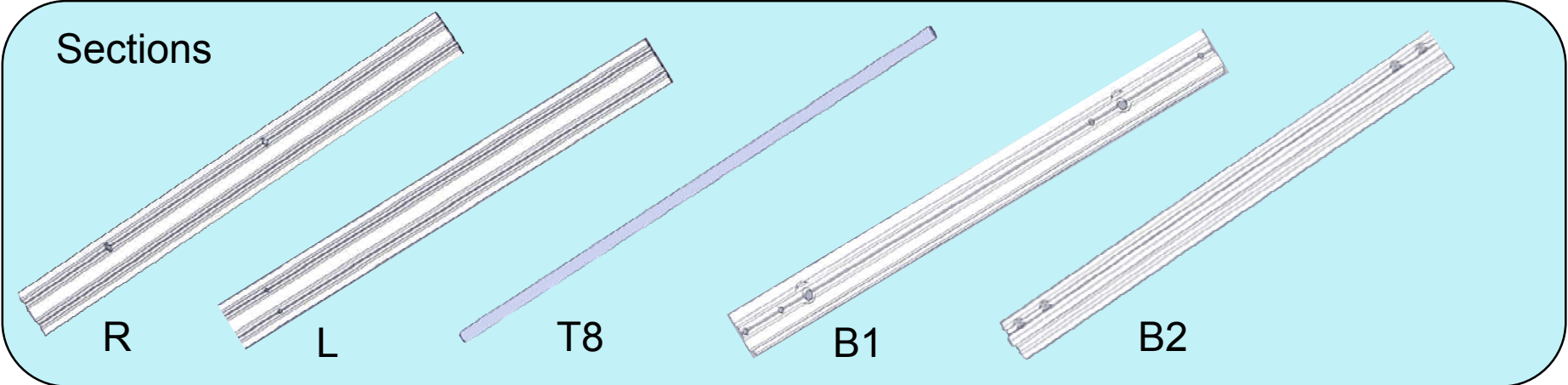

Step 1

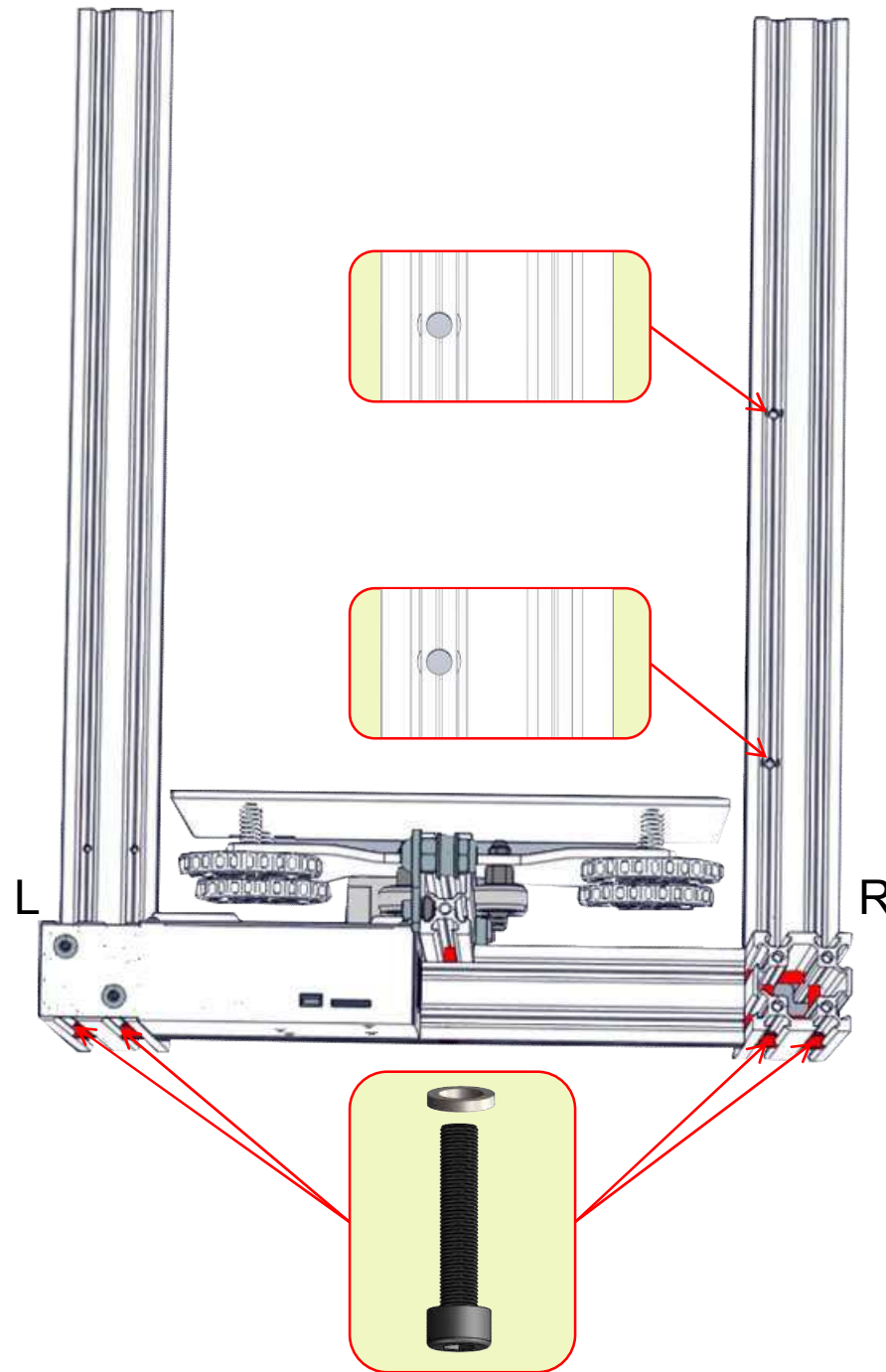
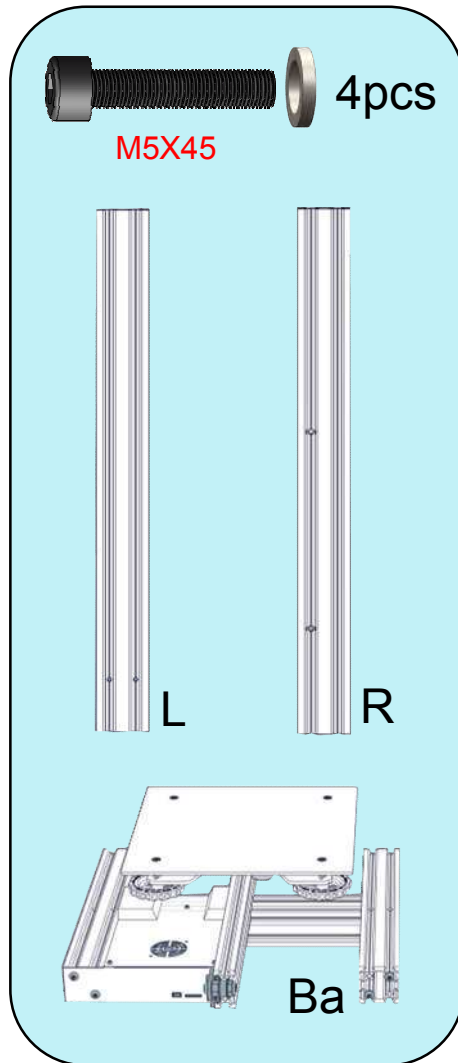

Step 2

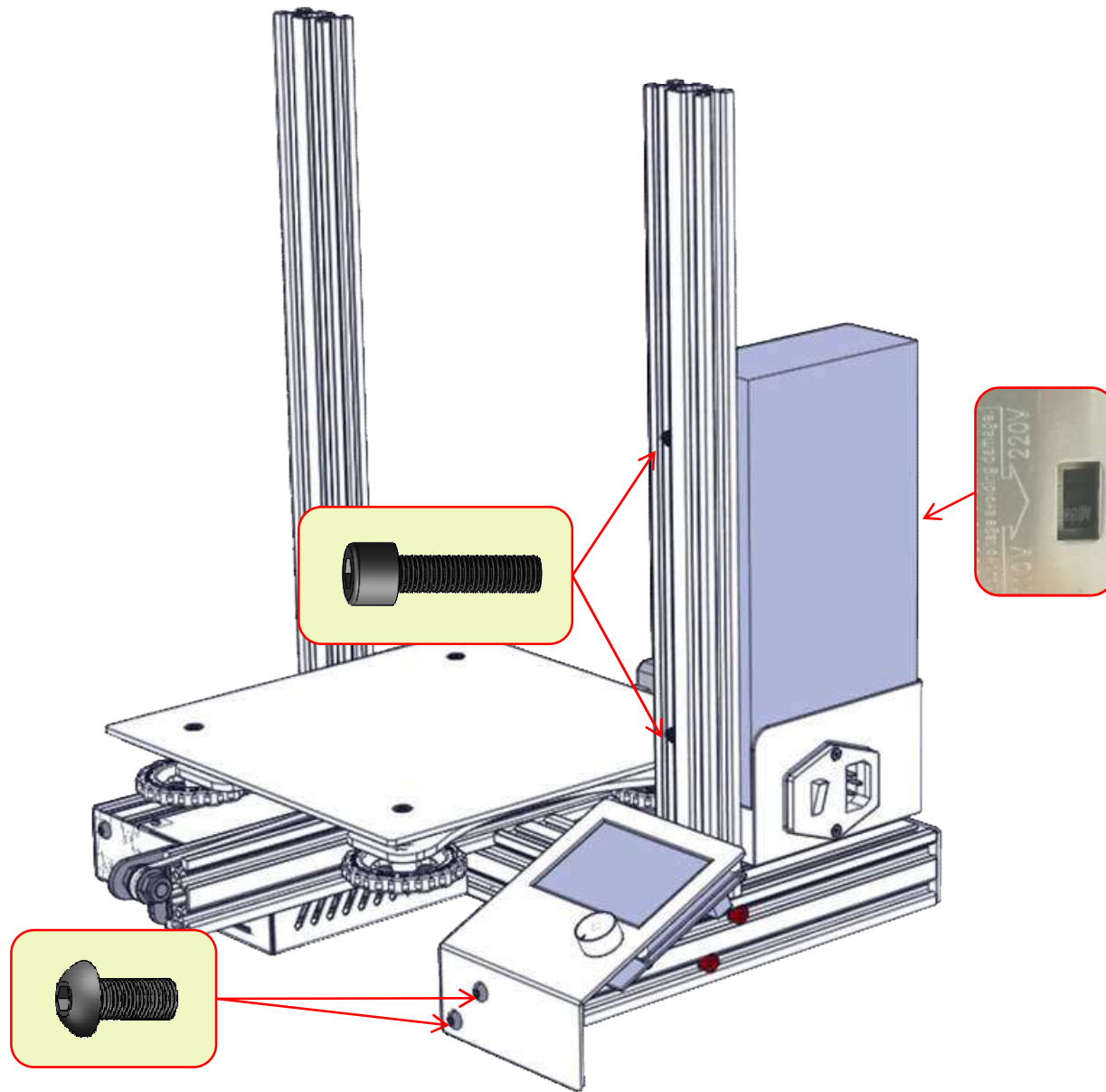
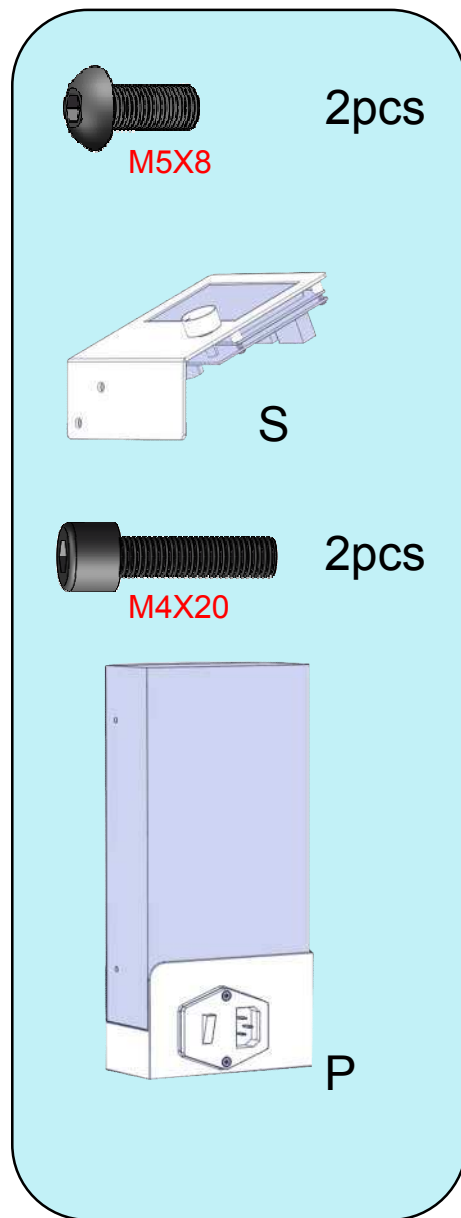

*Select the correct input voltage to match your local mains (220V or 110V).

Step 3

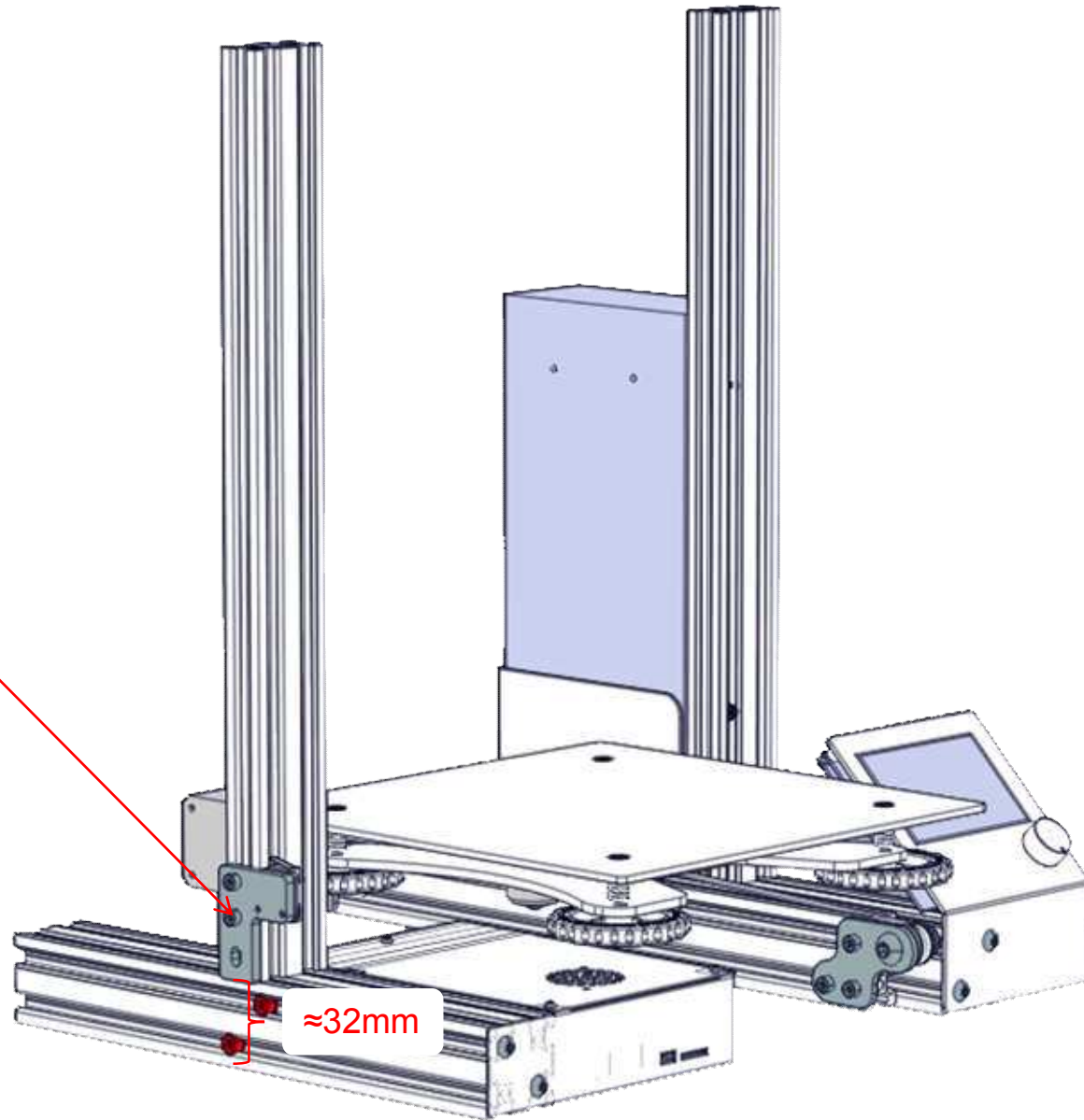
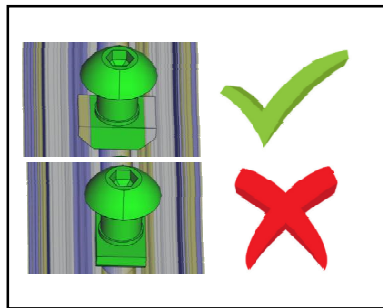
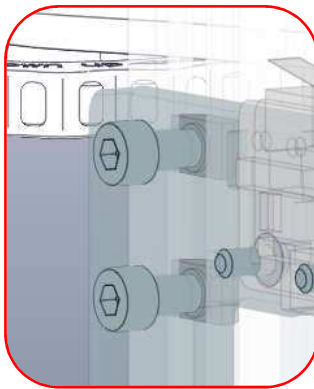
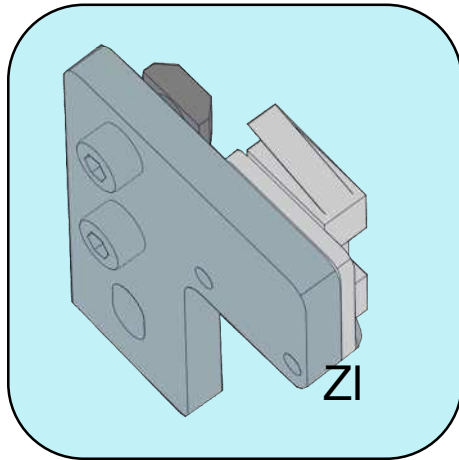

Step 4

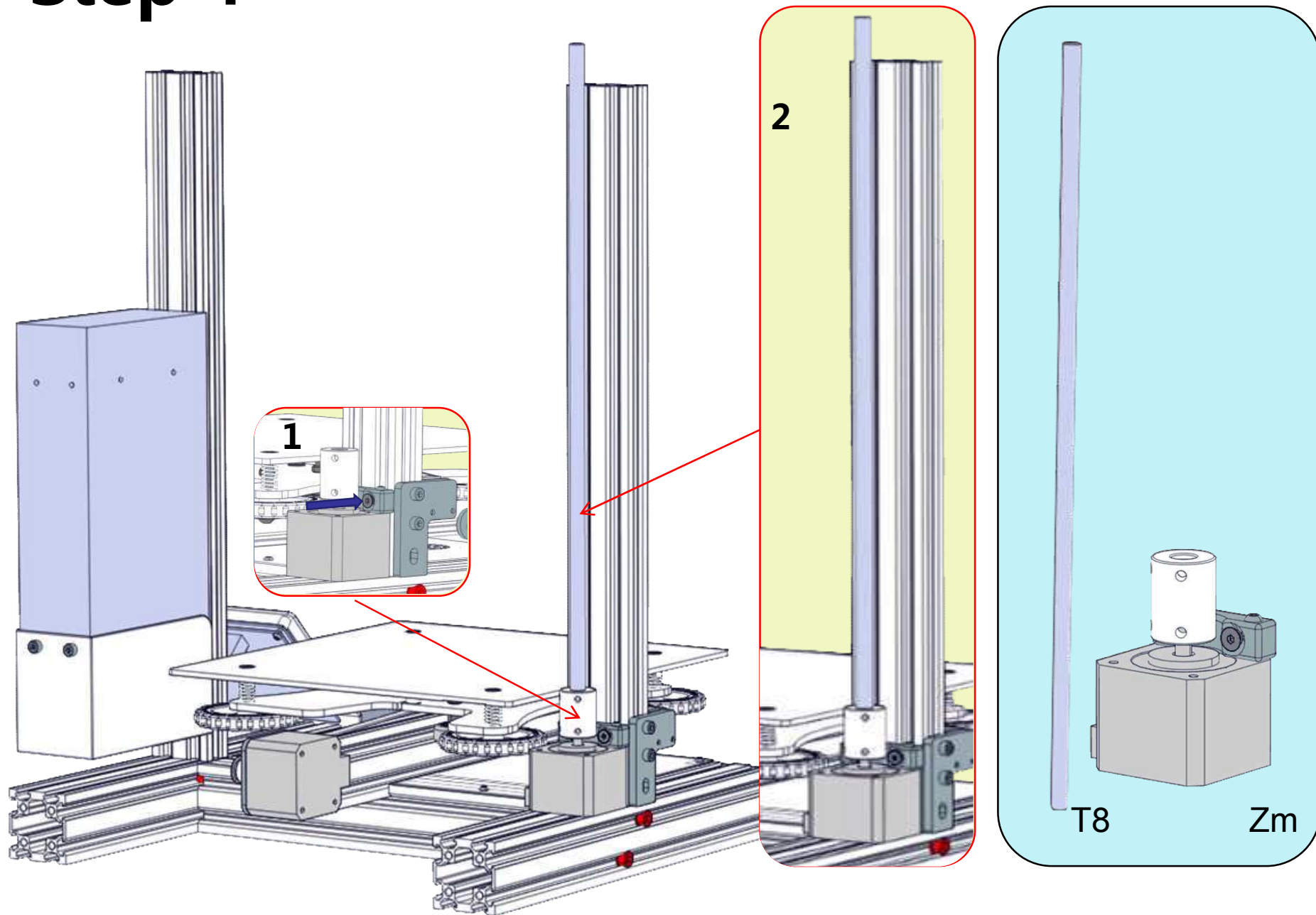

Step 5

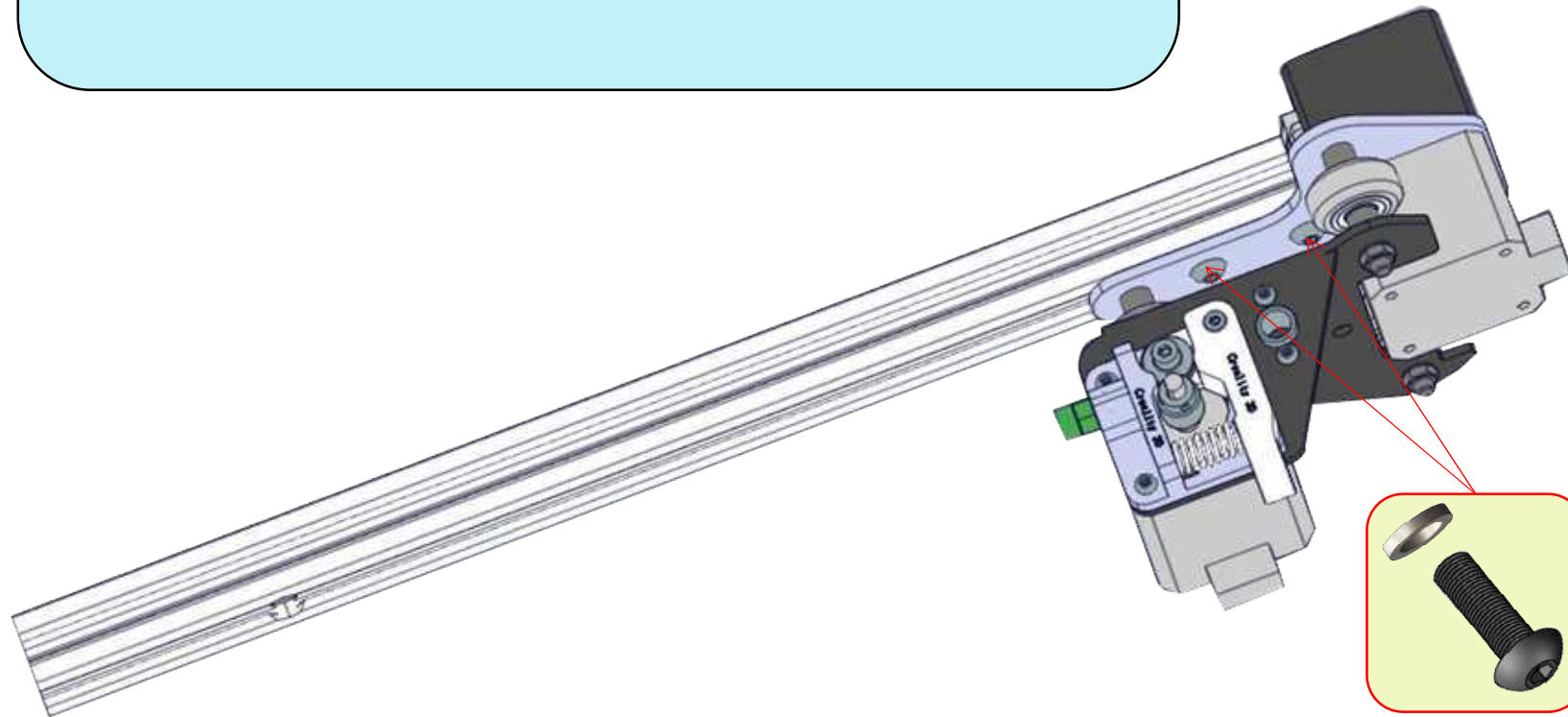
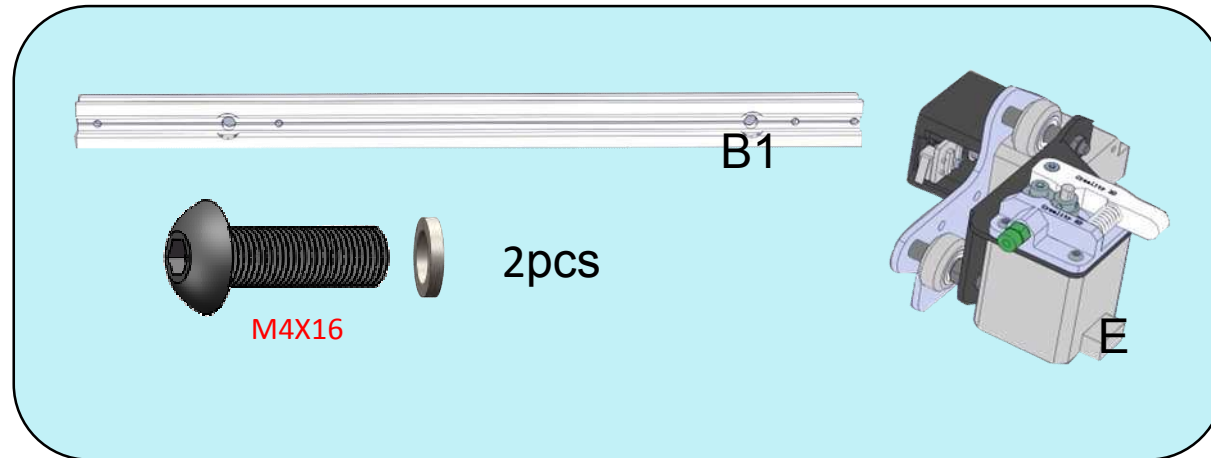

Step 6

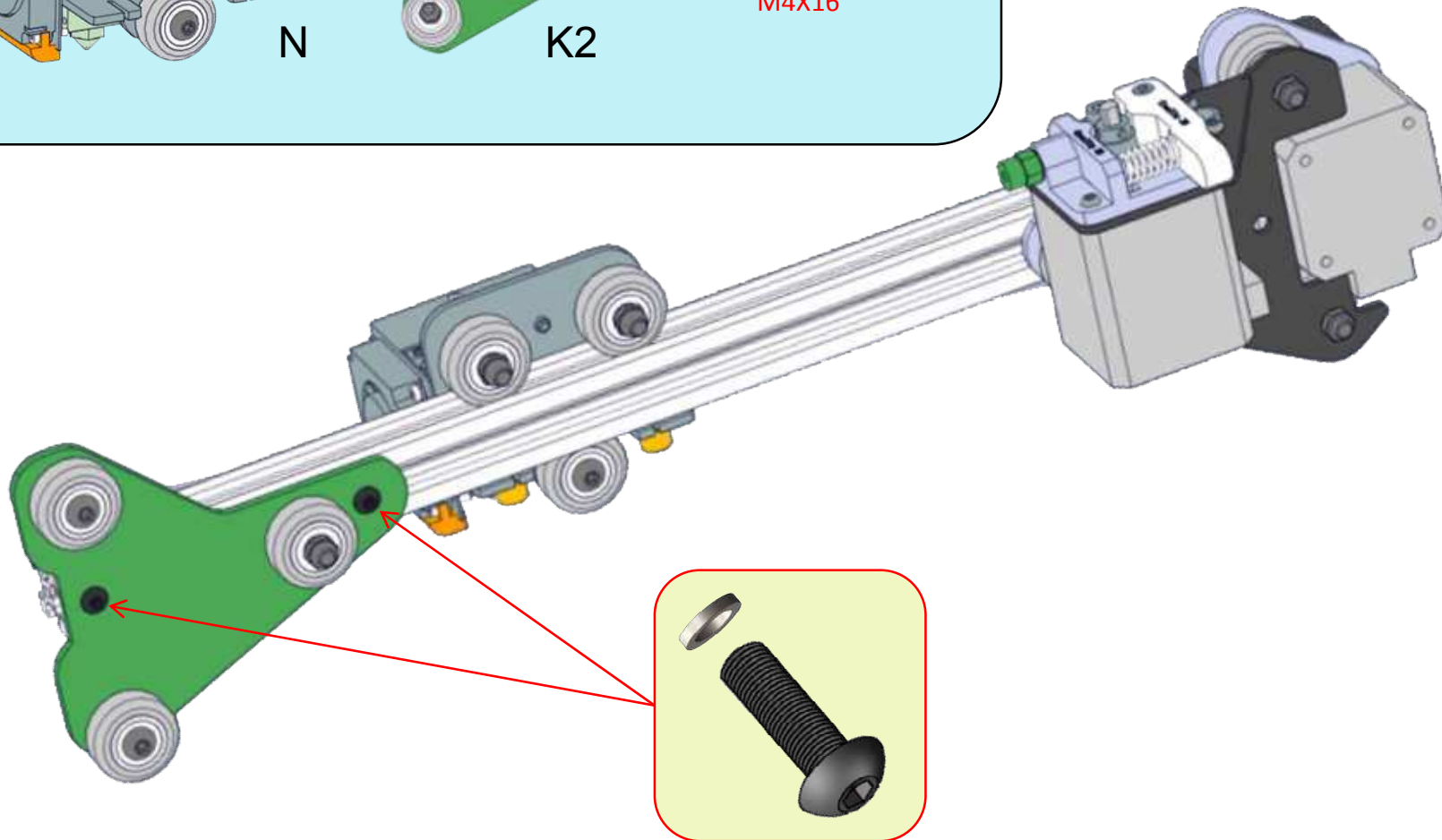
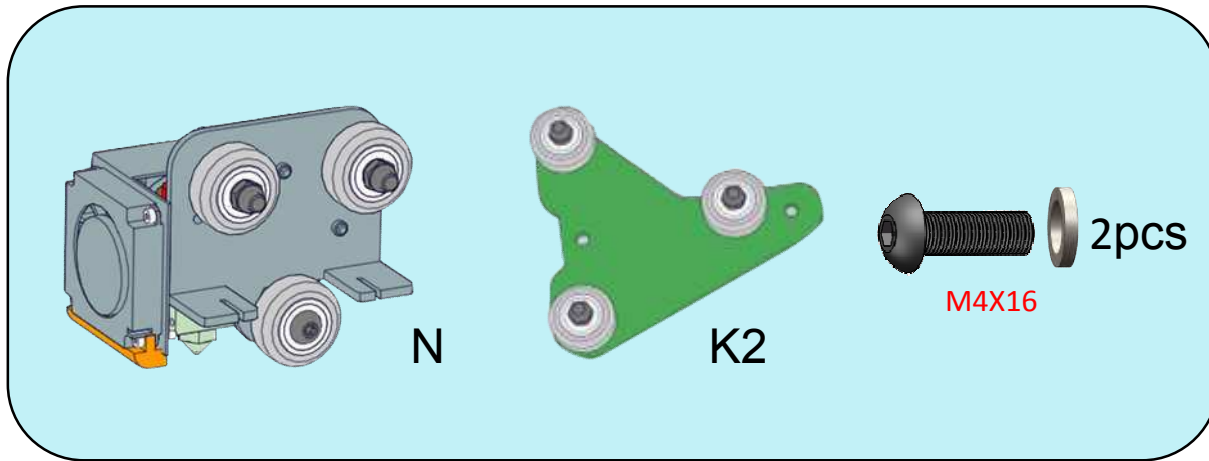

Step 7

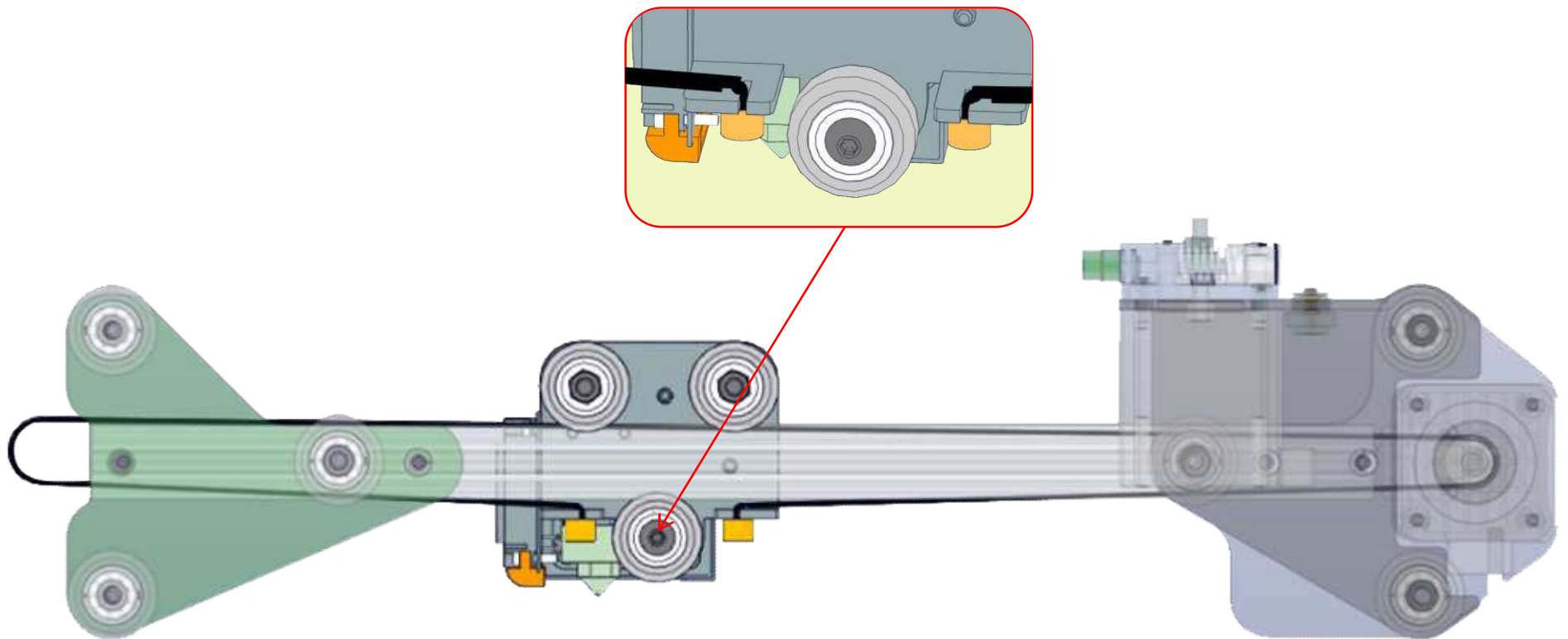
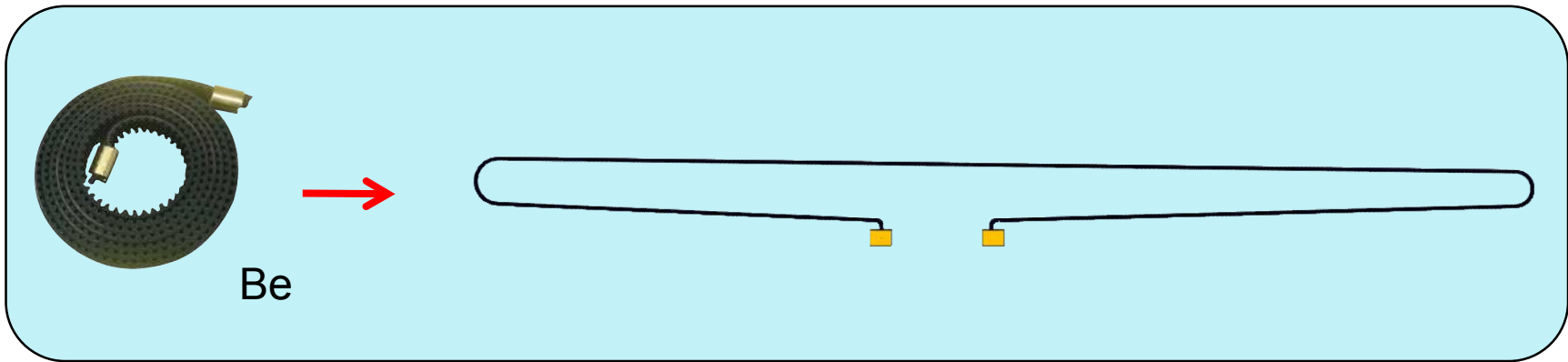

Step 8

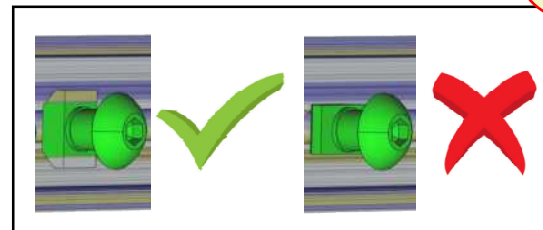
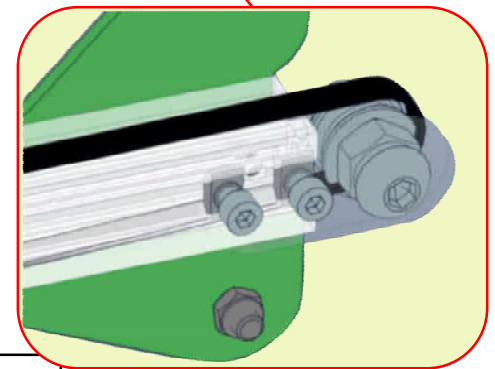
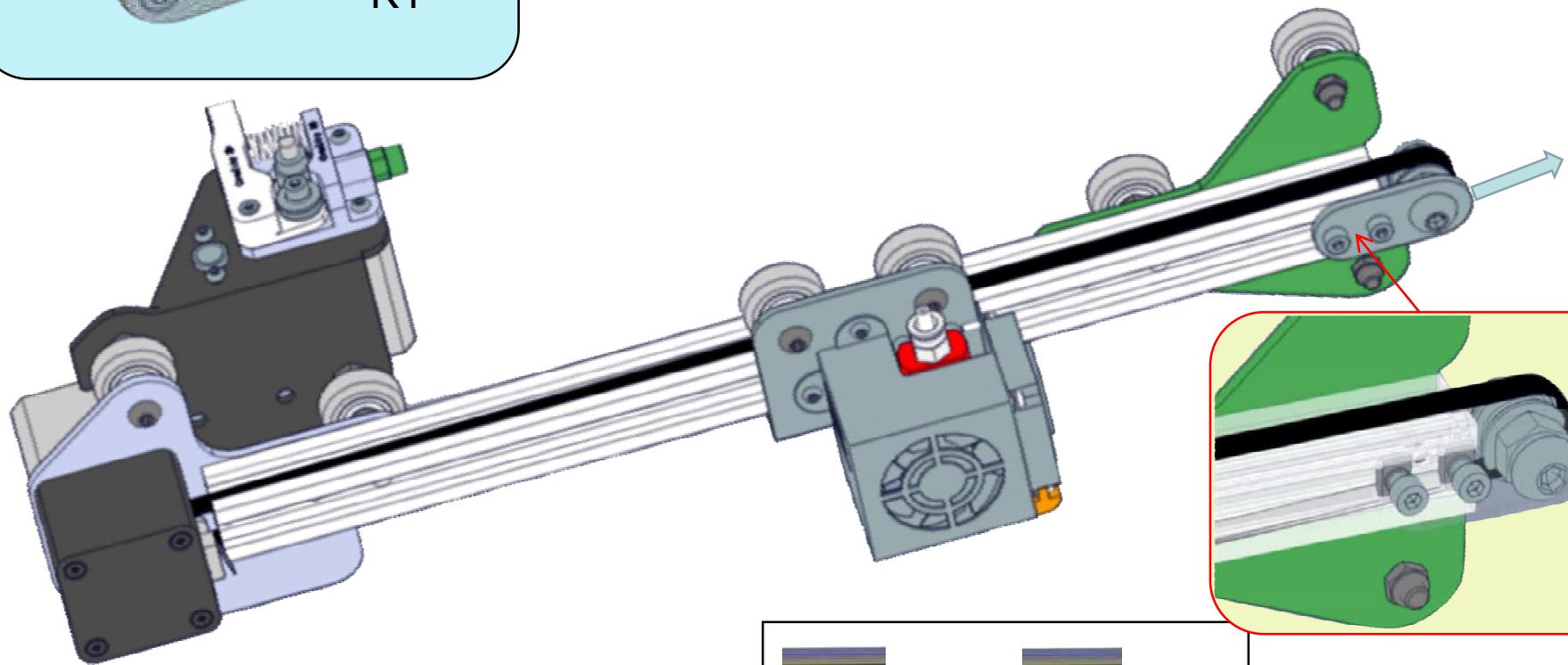
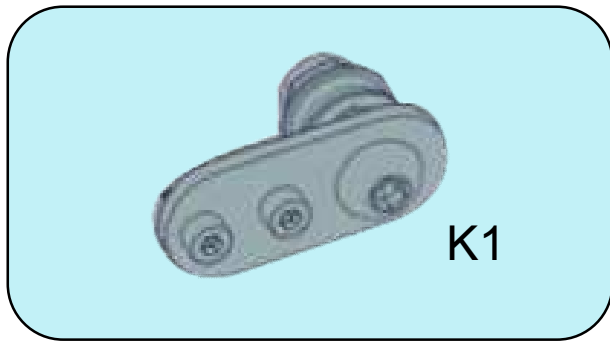

Step 9

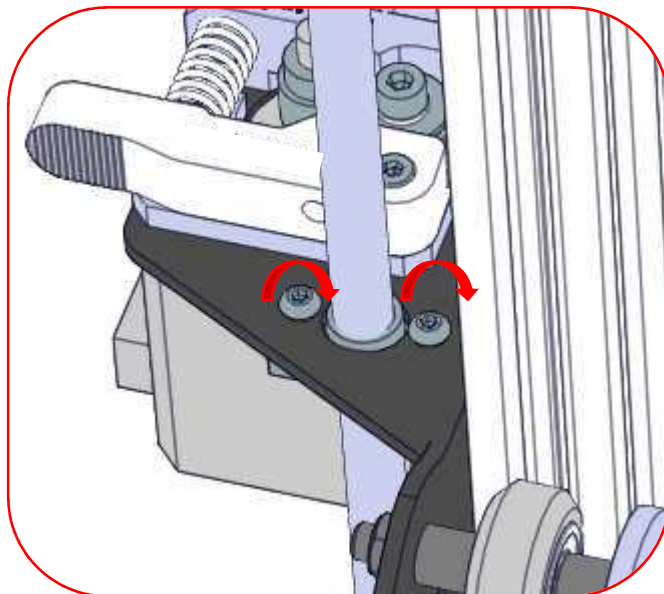
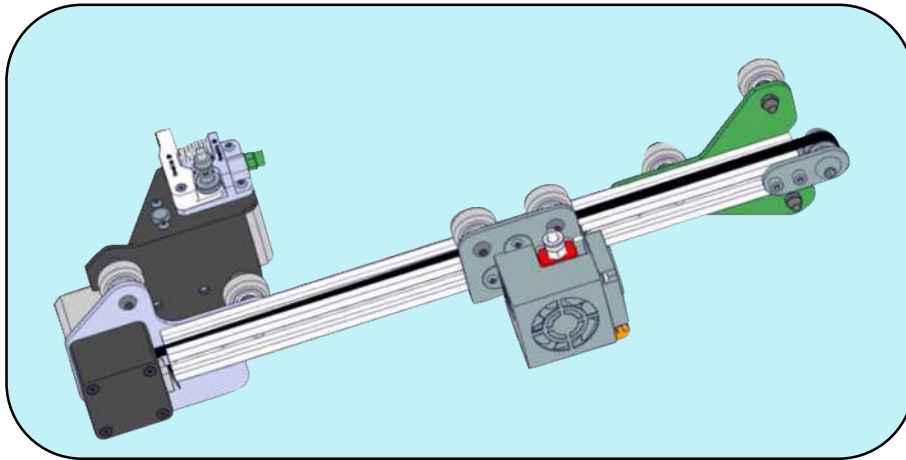

*Don't tighten it too tight

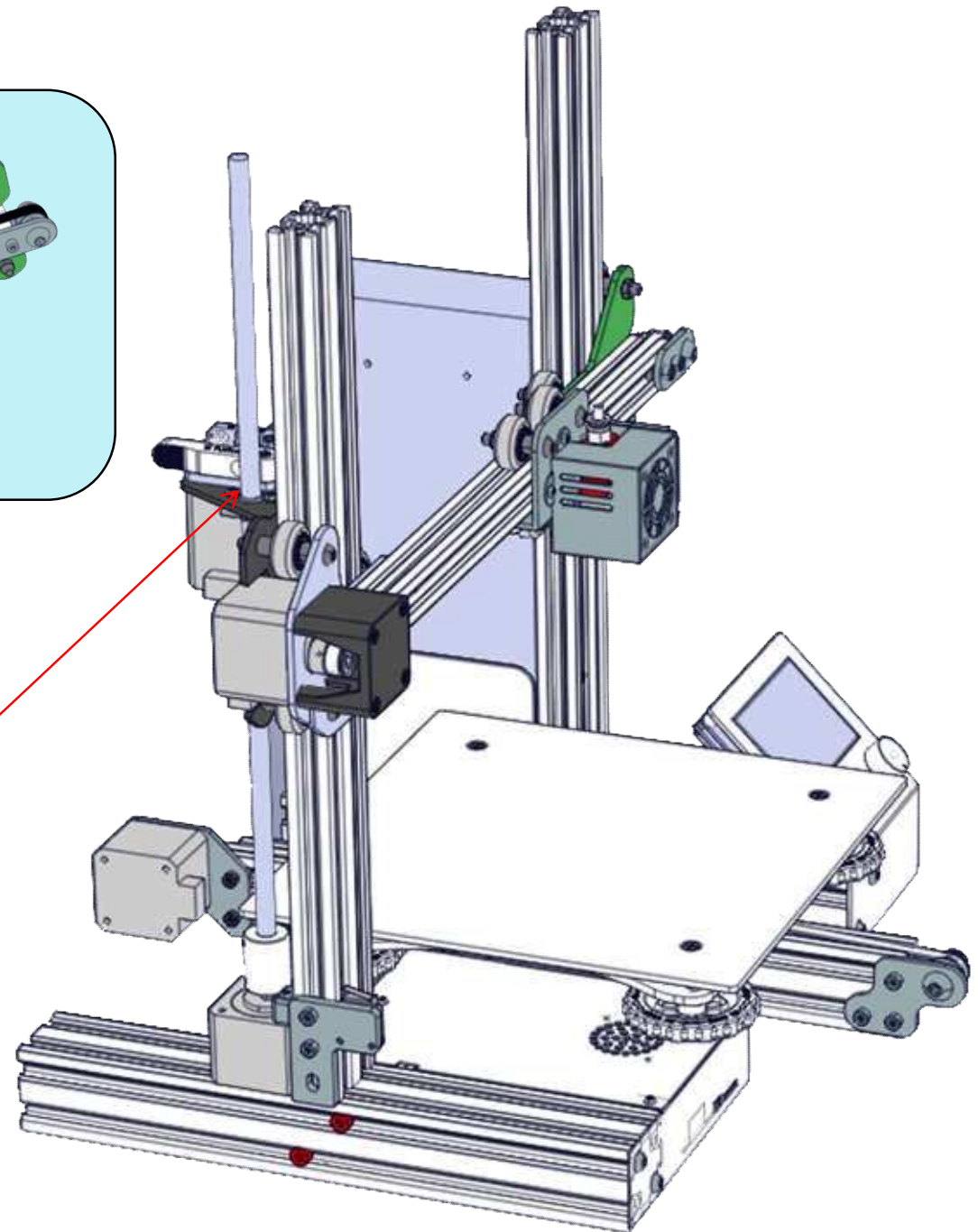

Step 10

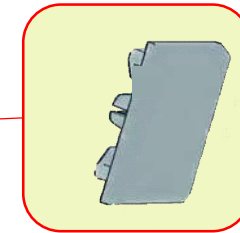
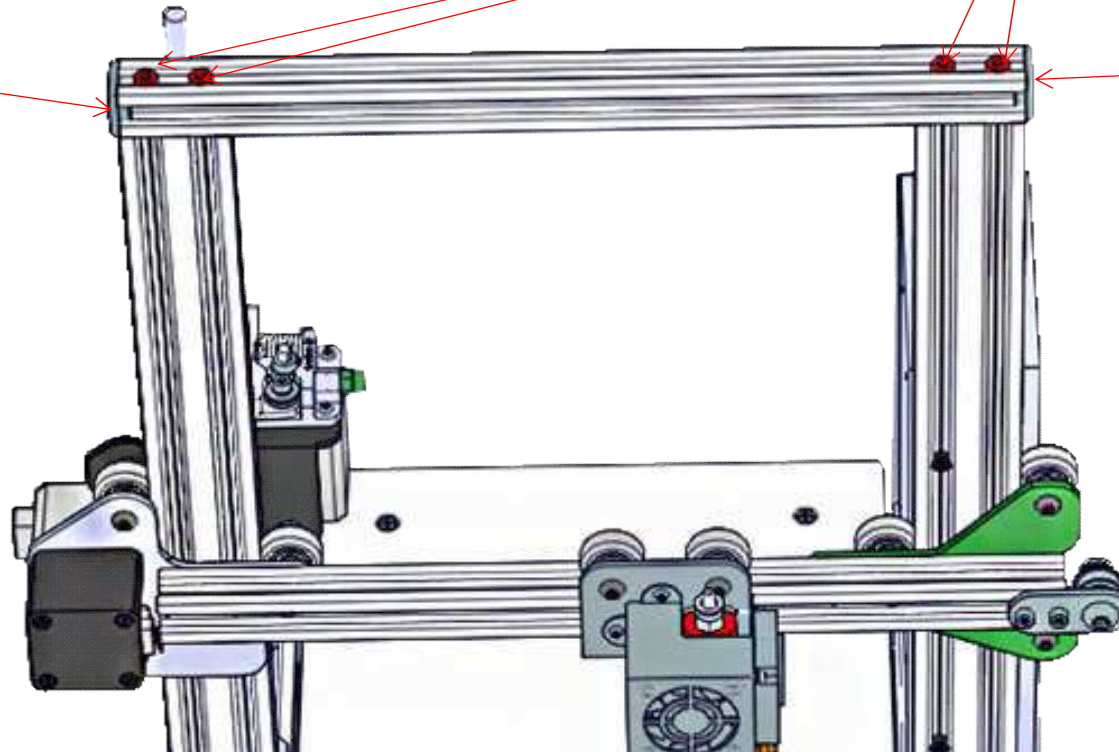
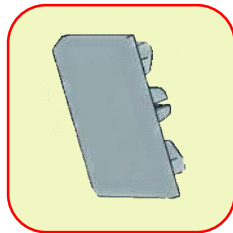
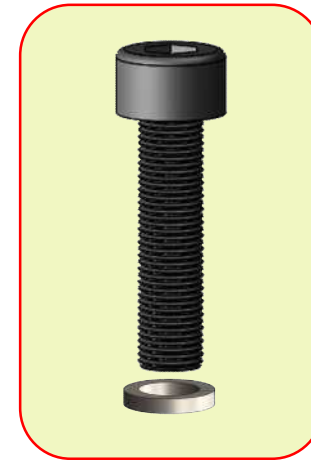
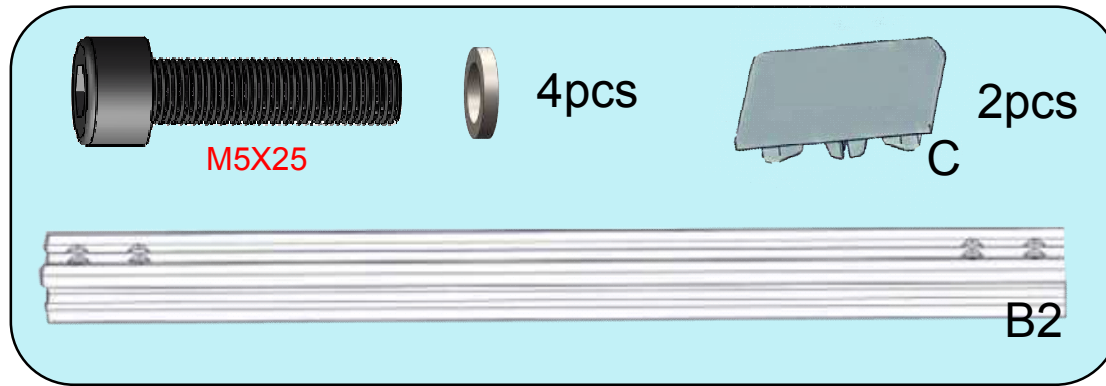

Step 11

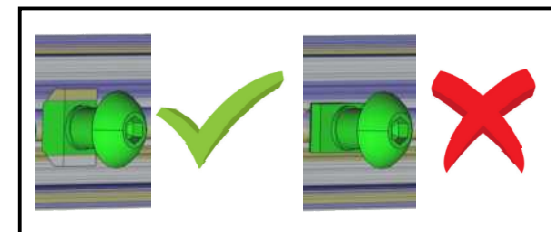
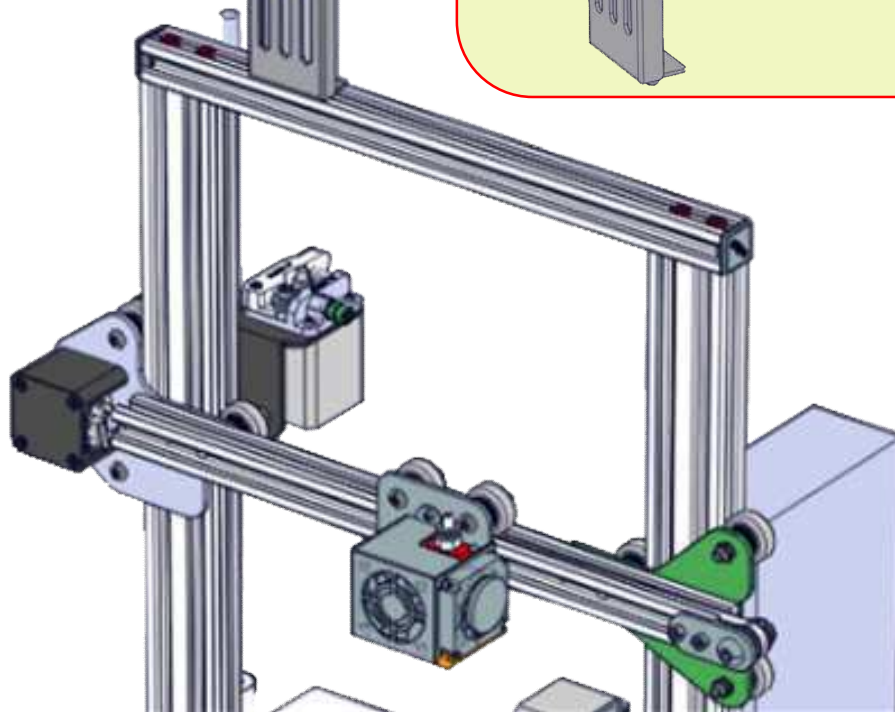
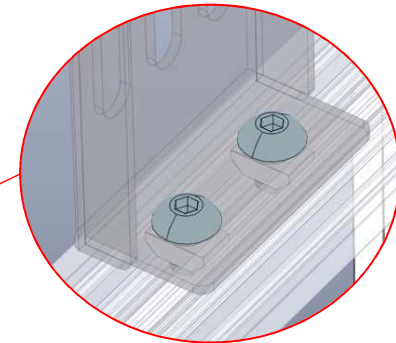
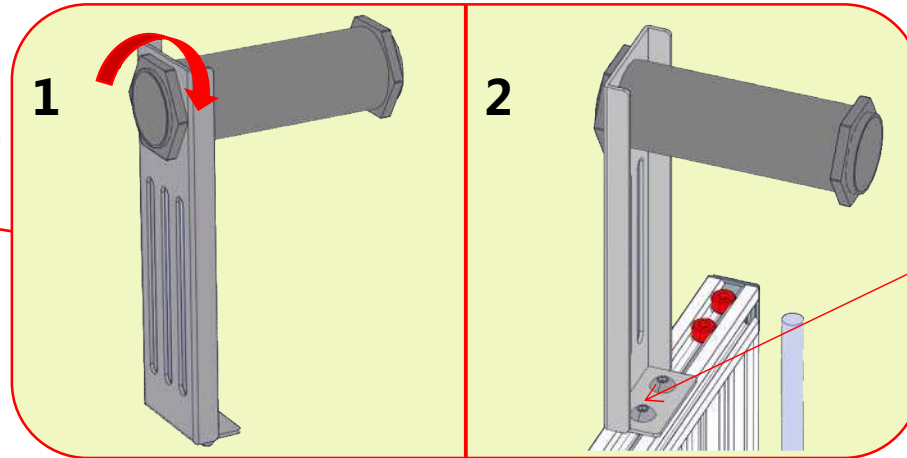
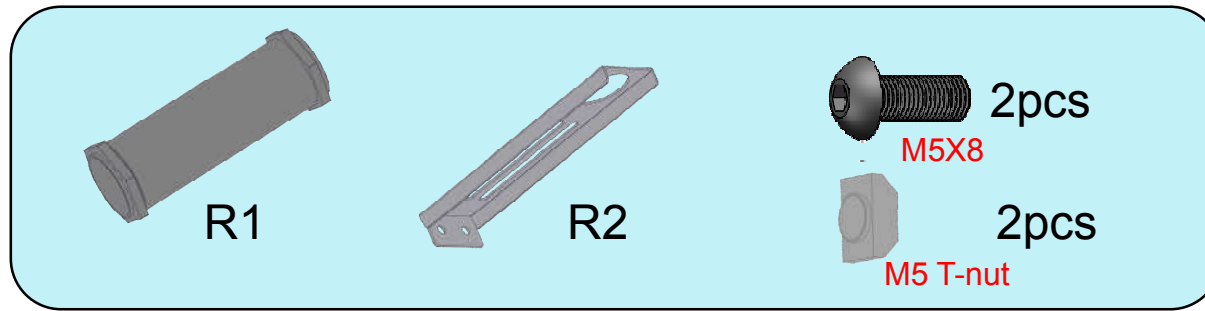

Step 12

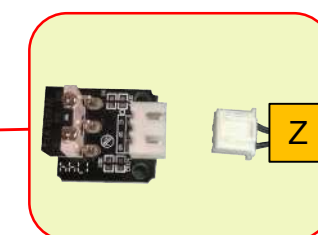
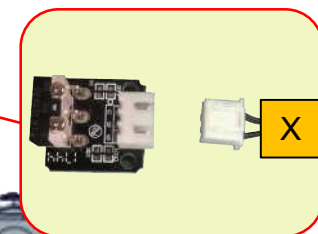
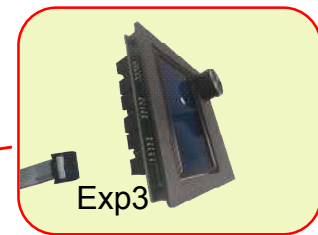
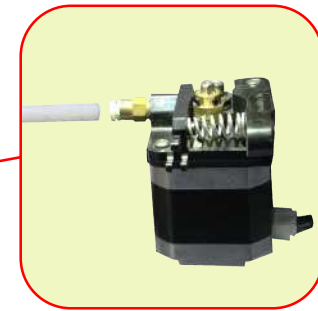
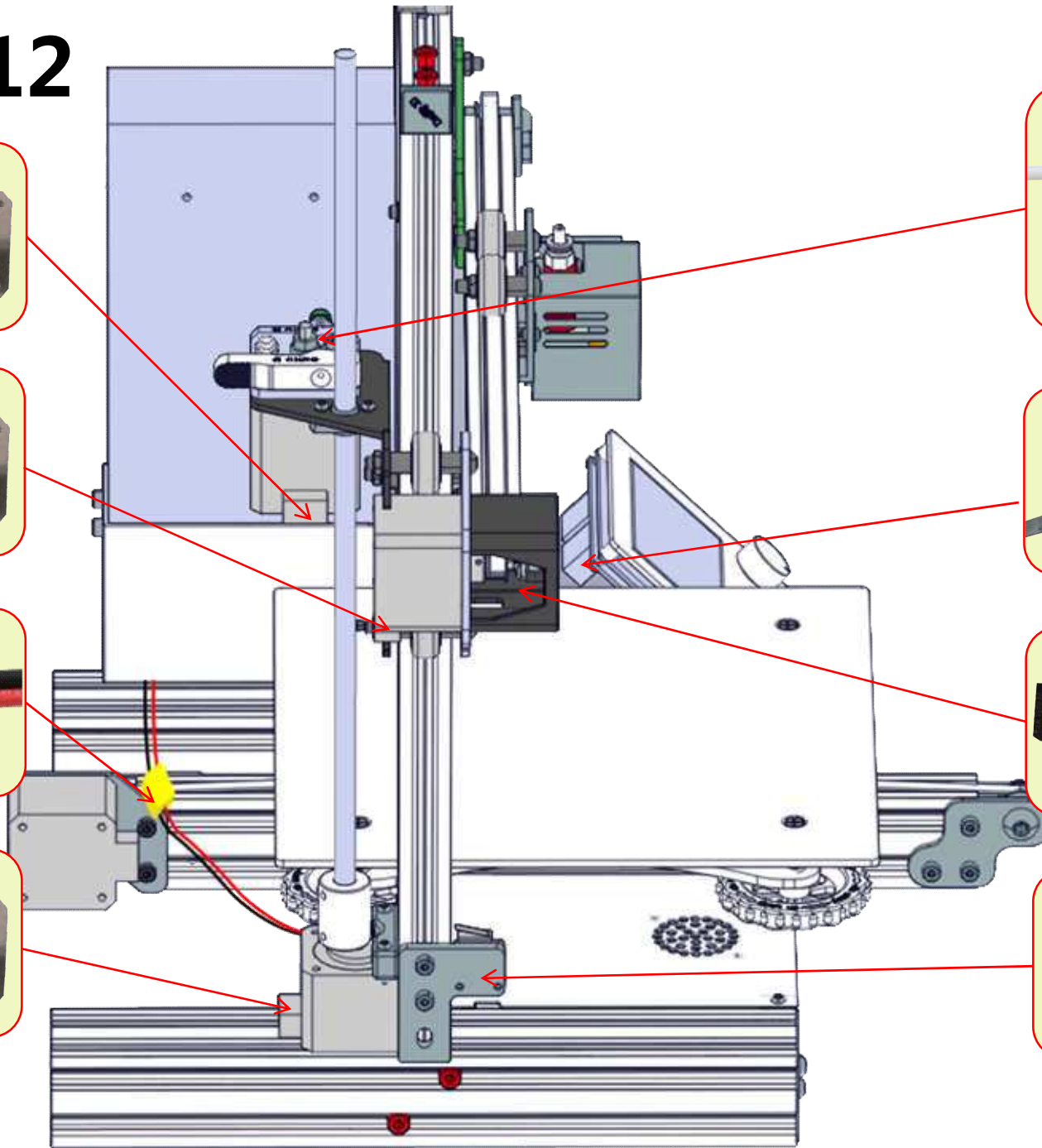
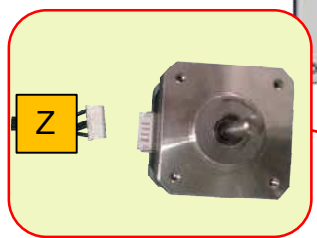
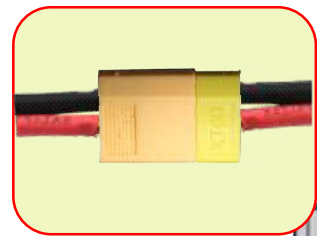
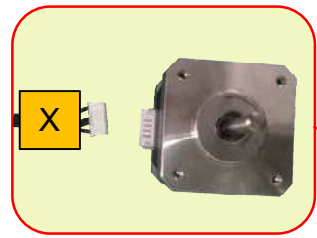
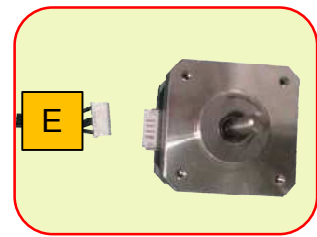



Shenzhen Creality3D Technology CO.,LTD.

Official Website: www.creality3d.com

Company Address: 12F, Building No.3, Jinchengyuan Industrial Area, Huafan Road,
Dalang, Longhua, Shenzhen, Guangdong Province

